



## Style 71

### Reducing Coupling



#### Features

- Reducing Coupling provides direct reduction on the piping-run, without any accessories
- Consists of reducing gaskets and a steel washer which prevents entry of the smaller pipe into the large pipe
- For general use (other than sprinkler systems) max. working pressure 500 psi. (35 bar).

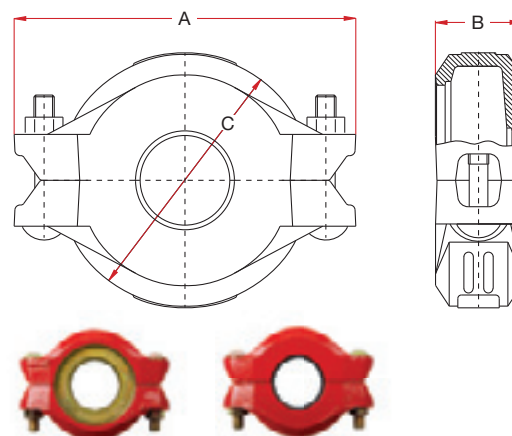

	Nominal Size	Pipe Outside Dia.	Coupling Dimensions			Bolts			Max. End Load ‡ kg	Allow Pipe End Sep. §	Weight Kg.
			A	B	C	No.	Size	x Length			
inch	2 x 1½	2.375 x 1.900	4 <sup>59</sup> / <sub>64</sub>	1 <sup>13</sup> / <sub>16</sub>	3 <sup>31</sup> / <sub>64</sub>	2	M10	x 57	299	0-½ 0-3.2	0.95
mm	50 x 40	60.3 x 48.3	125.0	46.0	88.5						
inch	3O.D x 2	3.000 x 2.375	5 <sup>59</sup> / <sub>64</sub>	1 <sup>13</sup> / <sub>16</sub>	4 <sup>9</sup> / <sub>64</sub>	2	M10	x 57	466	0-½ 0-3.2	1.20
mm	65 x 50	76.1 x 60.3	144.0	46.0	105.0						
inch	3 x 2	3.500 x 2.375	6 <sup>3</sup> / <sub>8</sub>	1 <sup>13</sup> / <sub>16</sub>	4 <sup>21</sup> / <sub>32</sub>	2	M12	x 76	466	0-½ 0-3.2	1.64
mm	80 x 50	88.9 x 60.3	162.0	46.0	118.5						
inch	3 x 3O.D.	3.500 x 3.000	6 <sup>3</sup> / <sub>8</sub>	1 <sup>13</sup> / <sub>16</sub>	4 <sup>21</sup> / <sub>32</sub>	2	M12	x 76	742	0-½ 0-3.2	1.50
mm	80 x 65	88.9 x 76.1	162.0	46.0	118.5						
inch	4 x 2	4.500 x 2.375	7 <sup>5</sup> / <sub>64</sub>	1 <sup>31</sup> / <sub>32</sub>	5 <sup>27</sup> / <sub>32</sub>	2	M12	x 76	466	0-¼ 0-6.4	2.63
mm	100 x 50	114.3 x 60.3	198.0	50.0	148.5						
inch	4 x 3O.D.	4.500 x 3.000	7 <sup>5</sup> / <sub>64</sub>	1 <sup>31</sup> / <sub>32</sub>	5 <sup>27</sup> / <sub>32</sub>	2	M12	x 76	742	0-¼ 0-6.4	2.50
mm	100 x 65	114.3 x 76.1	198.0	50.0	148.5						
inch	4 x 3	4.500 x 3.500	7 <sup>5</sup> / <sub>64</sub>	1 <sup>31</sup> / <sub>32</sub>	5 <sup>27</sup> / <sub>32</sub>	2	M12	x 76	1,012	0-¼ 0-6.4	2.37
mm	100 x 80	114.3 x 88.9	198.0	50.0	148.5						
inch	5½ O.D. x 4	5.500 x 4.500	9 <sup>59</sup> / <sub>64</sub>	2 <sup>3</sup> / <sub>64</sub>	7 <sup>5</sup> / <sub>64</sub>	2	M16	x 89	1,673	0-¼ 0-6.4	3.40
mm	125 x 100	139.7 x 114.3	245.5	52.0	180.0						
inch	6½ O.D. x 3	6.500 x 3.500	10 <sup>7</sup> / <sub>64</sub>	2 <sup>3</sup> / <sub>64</sub>	8 <sup>5</sup> / <sub>32</sub>	2	M16	x 89	1,012	0-¼ 0-6.4	4.45
mm	150 x 80	165.1 x 88.9	276.0	52.0	207.0						
inch	6½ O.D. x 4	6.500 x 4.500	10 <sup>7</sup> / <sub>64</sub>	2 <sup>3</sup> / <sub>64</sub>	8 <sup>5</sup> / <sub>32</sub>	2	M16	x 89	1,673	0-¼ 0-6.4	4.33
mm	150 x 100	165.1 x 114.3	276.0	52.0	207.0						
inch	6 x 3	6.625 x 3.500	10 <sup>7</sup> / <sub>64</sub>	2 <sup>3</sup> / <sub>64</sub>	8 <sup>5</sup> / <sub>32</sub>	2	M16	x 89	1,012	0-¼ 0-6.4	4.15
mm	150 x 80	168.3 x 88.9	276.0	52.0	207.0						
inch	6 x 4	6.625 x 4.500	10 <sup>7</sup> / <sub>64</sub>	2 <sup>3</sup> / <sub>64</sub>	8 <sup>5</sup> / <sub>32</sub>	2	M16	x 89	1,673	0-¼ 0-6.4	4.03
mm	150 x 100	168.3 x 114.3	276.0	52.0	207.0						
inch	8 x 6½ O.D.	8.625 x 6.500	13 <sup>39</sup> / <sub>64</sub>	2 <sup>23</sup> / <sub>64</sub>	10 <sup>31</sup> / <sub>64</sub>	2	M20	x 120	3,491	0-¼ 0-6.4	8.53
mm	200 x 150	219.1 x 165.1	345.0	60.0	266.0						
inch	8 x 6	8.625 x 6.625	13 <sup>39</sup> / <sub>64</sub>	2 <sup>23</sup> / <sub>64</sub>	10 <sup>31</sup> / <sub>64</sub>	2	M20	x 120	3,628	0-¼ 0-6.4	8.33
mm	200 x 150	219.1 x 168.3	345.0	60.0	266.0						

Suitable for dry pipe systems for temperature down to - 40°C.

► Note:

§ Figures indicating allowable pipe end separation refer to standard weight steel pipe with standard cut groove and in accordance with QUIKCOUP® pipe Preparation and Installation Instructions a. Figures for standard roll groove will be one half of the above values.

‡ Figures indicating max. end load refer to standard weight steel pipe with standard cut groove and in accordance with QUIKCOUP® pipe Preparations and Installation Instructions.