



02M



02DM



41M



42M



91M

Style 91M

Grooved End Fittings

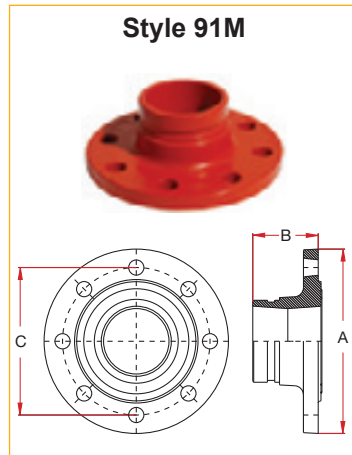

	Nominal Size	Pipe Outside Diam.	Style 91M Flange Adaptor			Bolts				Weight Kg
			A	B	C	ISO 7005-1		ANSI Class125	Size	
						PN10	PN16			
inch	2	2.375	6 1/2	2 29/64	4 59/64	4	4	-	M16	-
mm	50	60.3	165.0	62.0	125.0					
inch	3 O.D.	3.000	7 9/32	2 29/64	5 23/32	4	4	-	M16	-
mm	65	76.1	185.0	62.0	145.0					
inch	3	3.500	7 19/32	2 7/8	6	-	-	4	M16	-
mm	80	88.9	193.0	73.0	152.5					
inch	3	3.500	7 7/8	2 29/64	6 19/64	8	8	-	M16	3.78
mm	80	88.9	200.0	62.0	160.0					
inch	4	4.500	8 21/32	2 41/64	7 9/32	8	8	-	M16	5.70
mm	100	114.3	220.0	67.0	180.0					
inch	5 1/2 O.D.	5.500	9 27/32	2 41/64	5 1/2	-	8	-	M16	7.90
mm	125	139.7	250.0	67.0	210.0					
inch	6 1/4 O.D.	6.250	11 7/64	2 41/64	9 29/64	-	8	-	-	-
mm	150	165.1	282.0	67.0	240.0					
inch	6	6.625	11 7/32	2 41/64	9 29/64	-	8	-	M20	10.10
mm	150	168.3	285.0	67.0	240.0					
inch	8	8.625	13 1/2	3 5/64	11 5/8	8	-	-	M20	17.60
mm	200	219.1	340.0	78.0	295.0					
inch	8	8.625	13 3/8	3 5/64	11 5/8	-	12	-	M20	-
mm	200	219.1	340.0	78.0	295.0					
inch	10	10.750	15 35/64	3 1/8	13 25/32	12	-	-	M20	33.70
mm	250	273.0	395.0	79.0	350.0					
inch	10	10.750	15 63/64	3 1/8	13 63/64	-	12	-	M24	-
mm	250	273.0	406.0	79.0	355.0					
inch	12	12.750	18 1/8	3 11/32	16 9/64	-	12	-	M24	-
mm	300	323.9	460.0	85.0	410.0					

Maximum working pressure: 1000 psi (69 bar)

Style 02-D available with 1 1/2" & 2" drains